

Markus™ Electron Ionization Chamber, 0.055 cm³, Waterproof

Model 30-329

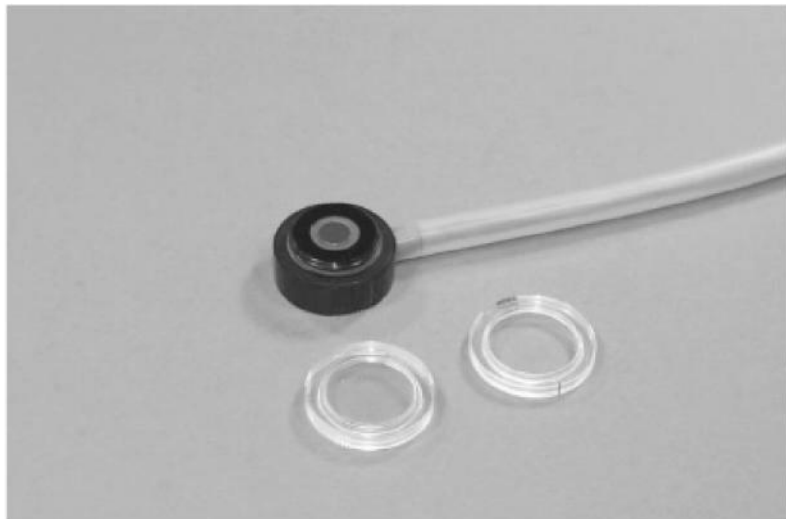

- Suitable for use in solid state phantoms and water phantoms
- Vented measuring volume
- Fully guarded up to measuring volume
- Touchable parts free of high voltage
- Extension cables up to 100 meters in length are available

The Markus chamber is the very first chamber specifically designed for electron dosimetry. The chamber may be used for measurements in water phantoms or solid state phantoms. A PMMA waterproofing cap, 0.87 mm thick (equivalent to 1 mm of water), and an annulus, for solid state phantom measurements, are included. The chamber's small measuring volume makes it ideal for electron measurements when very high spatial resolution is required. The diaphragm front allows measurements in the buildup region of electron fields to a depth of virtually zero. Markus includes a 3.4 ft (1.05 m) cable and BNC Triax connector.

Specifications

Volume 0.055 cm³
Response $2 \cdot 10^{-9}$ C/Gy
Leakage $\pm 2 \cdot 10^{-16}$ A
Polarizing voltage 300 V recommended, 400 V maximum
Cable length 3.4 ft (1.05 m)
Cable leakage $3.5 \cdot 10^{-12}$ C/(Gy • cm)
Wall material Polyethylene CH₂
Membrane thickness 0.03 mm
Area thickness 2.5 mg/cm²
Electrode Acrylic, graphite coated, 5.3 mm Ø
Nominal useful range 2 to 45 MeV
Range of temperature 10° to 40°C
Range of relative humidity 10% to 80%

Ion collection time

150 V 0.20 ms

300 V 0.09 ms

400 V 0.07 ms

Saturation behavior

Saturation behavior	Polarizing voltage	99.0% saturation	99.5% saturation
Maximum dose rate at continuous irradiation	150 V	5.9 Gy/s	2.9 Gy/s
	300 V	24.0 Gy/s	12.0 Gy/s
	400 V	42.0 Gy/s	21.0 Gy/s
Maximum dose rate per irradiation pulse	150 V	0.7 mGy	0.4 mGy
	300 V	1.4 mGy	0.7 mGy
	400 V	1.9 mGy	0.9 mGy

See next page for more specifications.

Specifications (cont)

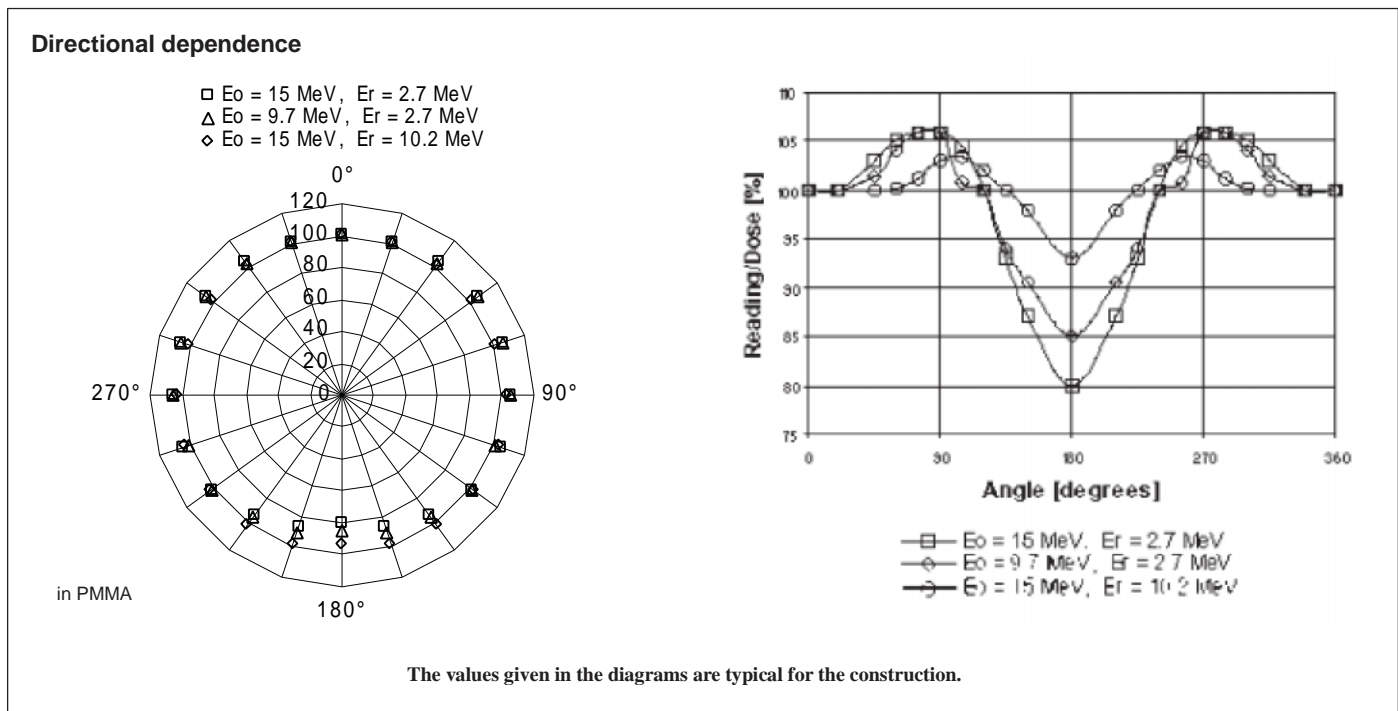
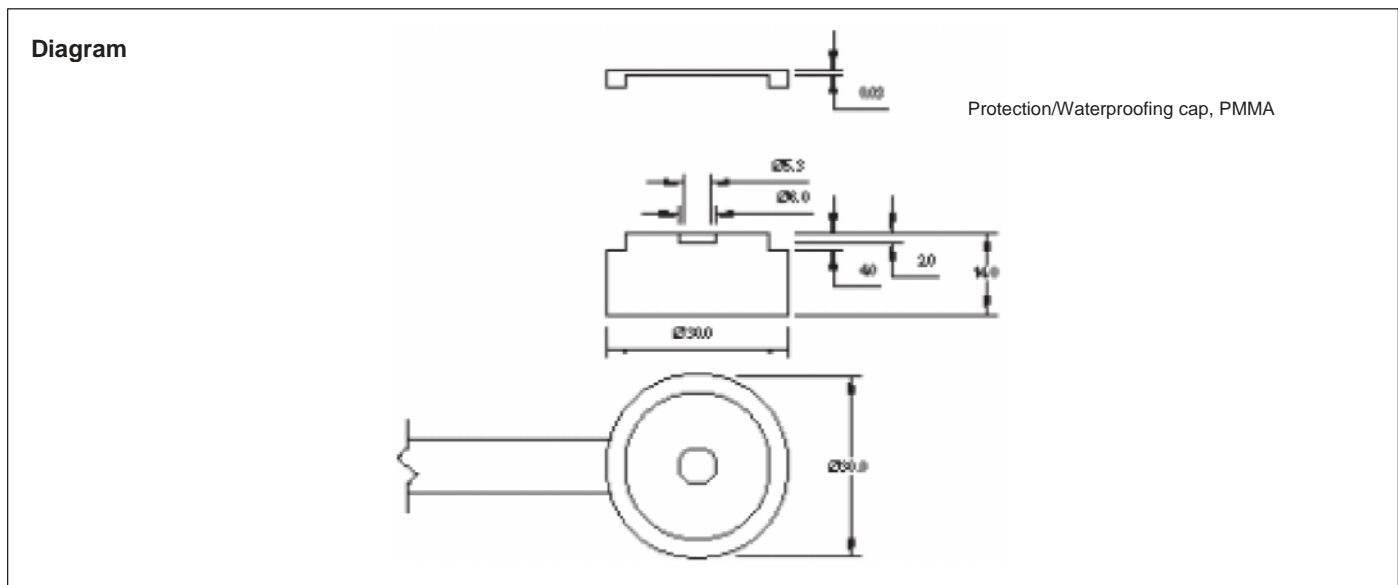

Available model(s)

30-329 Markus Electron Ionization Chamber, 0.055 cm^3 ,
Waterproof, includes BNC Triax connector and PMMA buildup cap

Other types of triaxial cable connectors available

For more information or to receive our full product catalog, contact **Fluke Biomedical** at 440.248.9300 or www.flukebiomedical.com/rms.

Specifications are subject to change without notice.

©2005, 2006 Fluke Biomedical. All rights reserved. Markus is a trademark of PTW New York and PTW Freiburg. Printed in USA.
30-329-ds rev 3 06 mar 06